

CONNECTIONS FOR SINGLE GUN OR MACHINE

SELECT SINGLE OR DUAL GUN OPERATION IN TIMER CONFIGURATION FILE

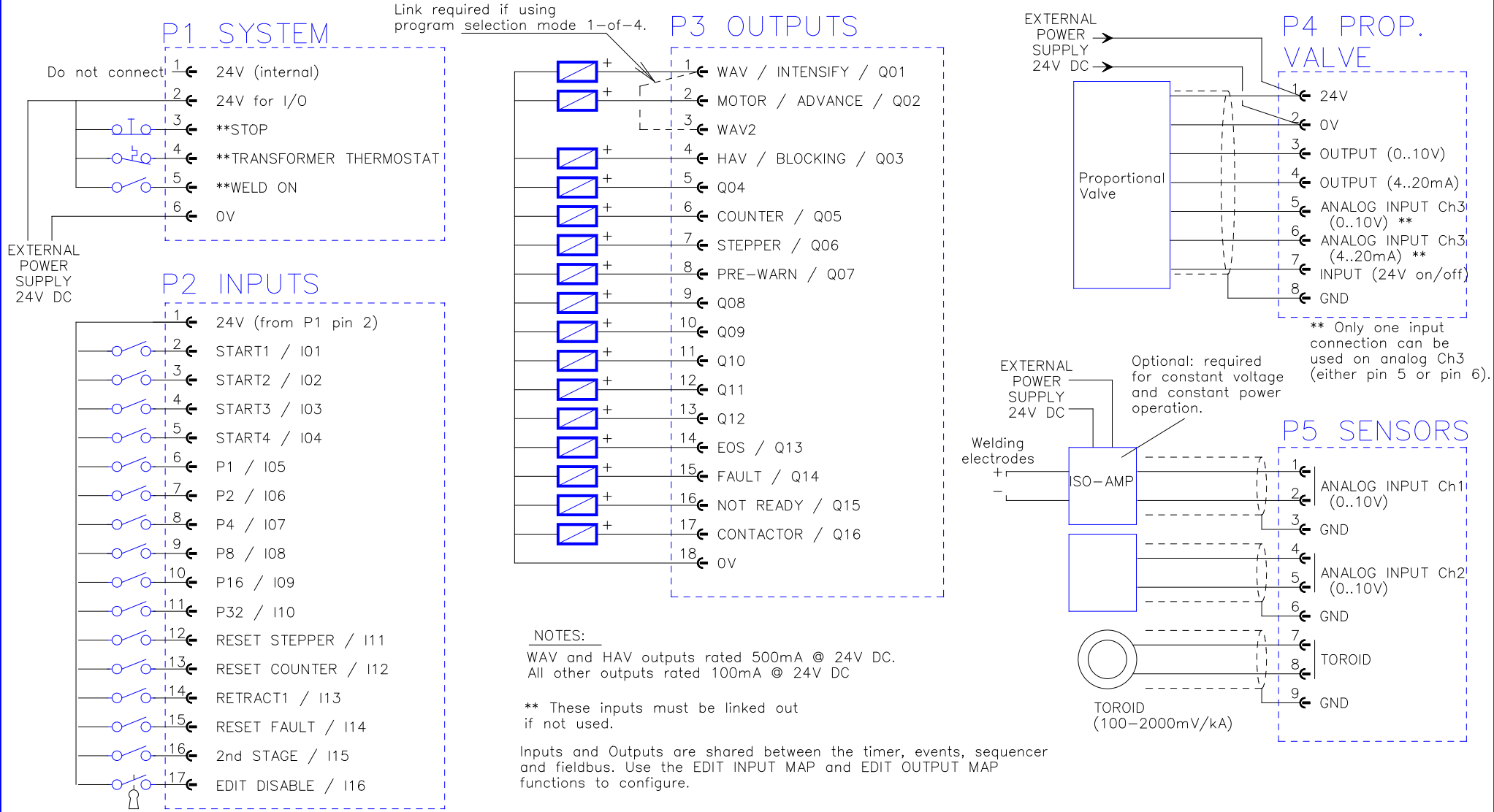

DATE:	17-2-15
DRAWN:	K.C.
CHECKED:	

BF ENTRON LTD

TITLE: iPAK USERS CONNECTIONS

DRAWING No:	3U3422
ISSUE No:	6
SHEET No:	1 of 3

CONNECTIONS FOR DUAL GUN OPERATION

SELECT SINGLE OR DUAL GUN OPERATION IN TIMER CONFIGURATION FILE

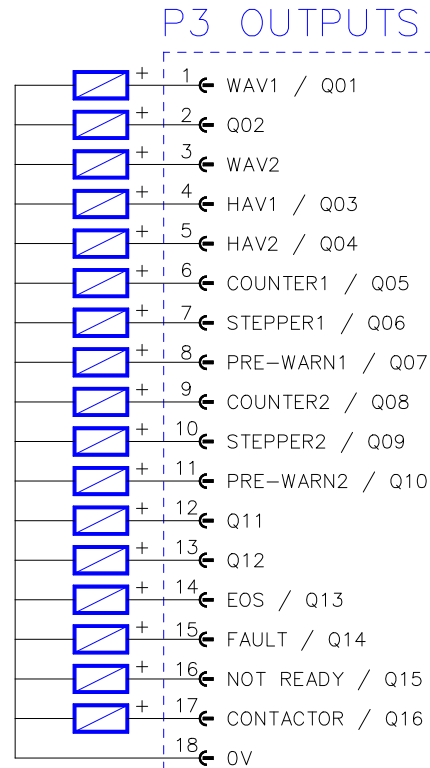
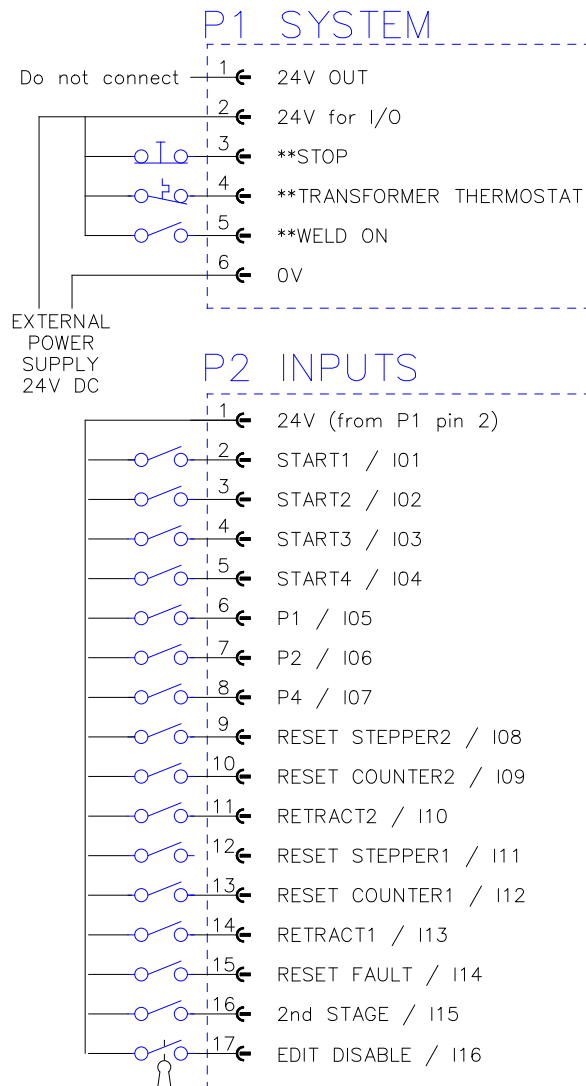

NOTES:

WAV and HAV outputs rated 500mA @ 24V DC.
 All other outputs rated 100mA @ 24V DC

** These inputs must be linked out if not used.

Inputs and Outputs are shared between the timer, events and sequencer. Use the EDIT INPUT MAP and EDIT OUTPUT MAP functions to configure.

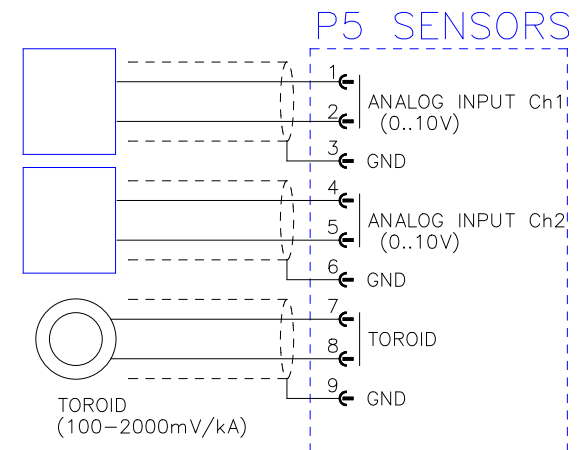
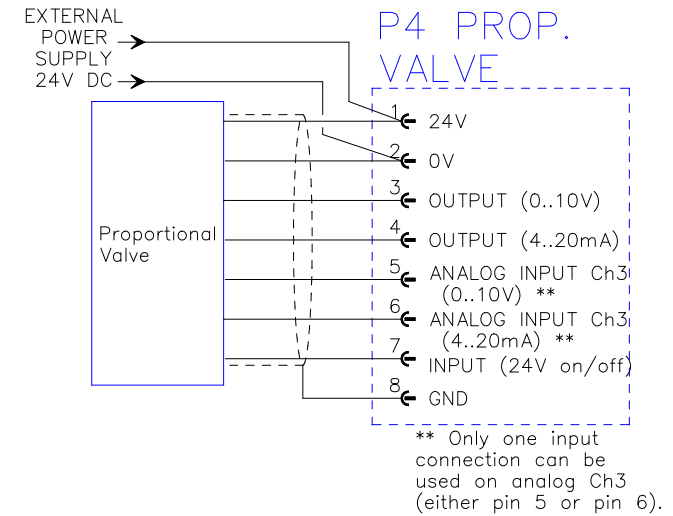

DATE: 17-2-15

DRAWN: K.C.

CHECKED:

BF ENTRON
LTD

TITLE:

iPAK
USERS CONNECTIONS

DRAWING No:

3U3422

ISSUE No: 6

SHEET No: 2 of 3

CONNECTIONS FOR MULTI GUN OR CASCADE

SELECT MULTI GUN OR CASCADE OPERATION IN TIMER CONFIGURATION FILE

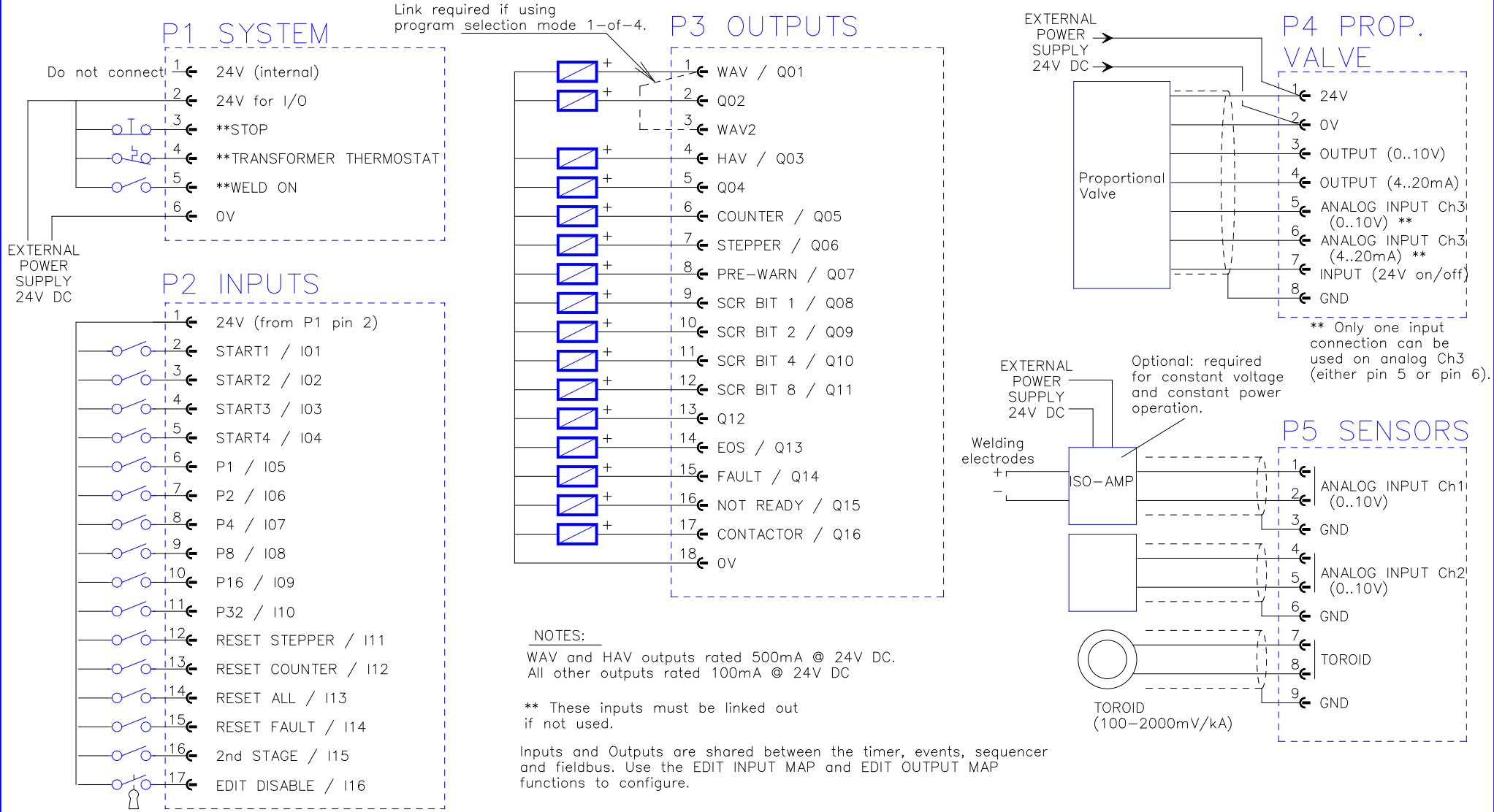

DATE:	17-2-15
DRAWN:	K.C.
CHECKED:	

BF ENTRON LTD

TITLE: iPAK USERS CONNECTIONS

DRAWING No:	3U3422
ISSUE No:	6
SHEET No:	3 of 3