

# SK-54 Micro-computer based Constant current welding controls



**FORWEL**

## Ratings and Specifications

ITEM		SK-54V, SK-54H
Weld Power		200~240VAC/380~480VAC, 50/60Hz
Control Power		100~240VAC (Free Voltage), 50/60Hz
Control Method		Secondary feed-back constant current control
Control Speed		1/2 cycle
Current Accuracy		±2%
Indication		7-Segment LED Display
Program Parameters	SCHEDULE	15 schedules
	SQUEEZE	0 ~ 99 cycles
	WELD 1	
	COOL 1	0 ~ 9 cycles
	UP SLOPE	
	WELD 2	0 ~ 99 cycles
	COOL 2	0 ~ 99 cycles (0~99 half cycles)
	WELD 3	0 ~ 99 cycles
	DOWN SLOPE	0 ~ 9 cycles
	HOLD	0 ~ 99 cycles
	OFF/PULSATION	0 ~ 99 cycles / 0 ~ 9 times
VALVE		7 operations
Maximum Current Setting Range		3.0 ~ 80.0KA
Current Setting Range		15 Schedules Constant Current Control Mode (0.3KA ~ 80.0KA) Current <sub>1,2,3</sub> : 10% ~ 100% of Maximum Current Setting
Current Monitor	Setting of Upper Limit	15 Schedules, ±0 ~ 49%
	Setting of Lower Limit	
Valve Output	System	Valve No.1 or 2 and be selected for 15 schedules and 7 operations
	Output	Control Voltage Output or Free Valve
Stepper Up of Current	Step No.	0 ~ 9
	Step Count	0 ~ 9999
	Step Up Rate	50 ~ 200%
Counter	Weld Count	0 ~ 99
	Work Count	0 ~ 9999
	Total Count	0 ~ 9999
External Input (Dry contact or open collector)		Program Lock Switch
		Start 1, 2, 4, 8 Switch
		Weld ON/OFF Switch
		Weld Transformer or SCR Temperature Limit Switch
		Step Reset Switch
		Error Reset Switch
		Interlock / Weld No. Switch
External Contact Output (250V 0.5A Max.)		Hold End Output
		Error Output
		Step End Output
		Interlock / Weld No. Error Output
Memory Retention		More than 10 years after power failure
Serial Output (Optional)		RS232 / RS485 Interface
Dimensions	SK-54V	85mm(W) x 260mm(H) x 207mm(D) 3.3"(W) x 10.2"(H) x 8.1"(D)
	SK-54H	260mm(W) x 85mm(H) x 207mm(D) 10.2"(W) x 3.3"(H) x 8.1"(D)
Toroidal Coil		TC-450L, TC-600L (Optional)

## Versatile, easy-to-operate, micro-computer control unit.

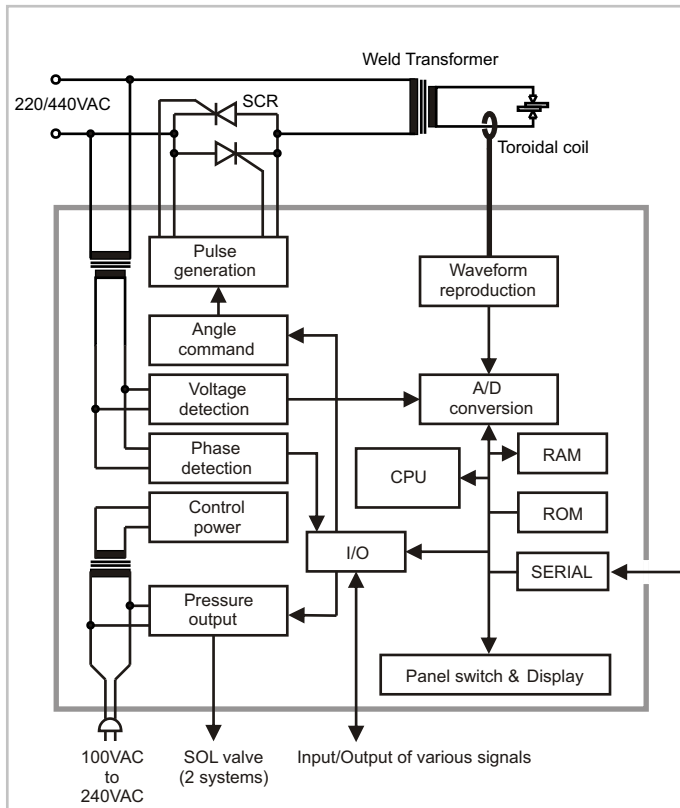

### Constant current feed-back theory

Using a toroidal coil, the current wave form is reconstructed from the output signal. It is then transformed into an RMS effective value using the following formula:

$$RMS = \sqrt{\frac{1}{T} \int_0^T (i)^2 dt}$$

The control then compares this effective value with the set current value. The weld current is corrected with every half cycle through phase conversion and trigger pulse oscillation.

The result is smooth, consistent secondary welding current delivered at the weld regardless of the line voltage fluctuations.



### Selection Table :

#### SK54V – AC

#### Pressure Valve output

AC : Control Voltage Output  
FV : Free Valve

#### Product name

SK54V : Vertical type  
SK54H : Horizontal type

- Control power : 100~240VAC

- Welding power : 200~240VAC and 380~480VAC

# FORWEL

34-10, Sinseon-ro 329 beon-gil, Nam-gu, Busan, Korea  
Website: [www.forwel.com](http://www.forwel.com) Email: [info@forwel.com](mailto:info@forwel.com)